

13"-27" display Interactive, counterbalance dual-monitor arm

DELTAACO
A NORDIC BRAND

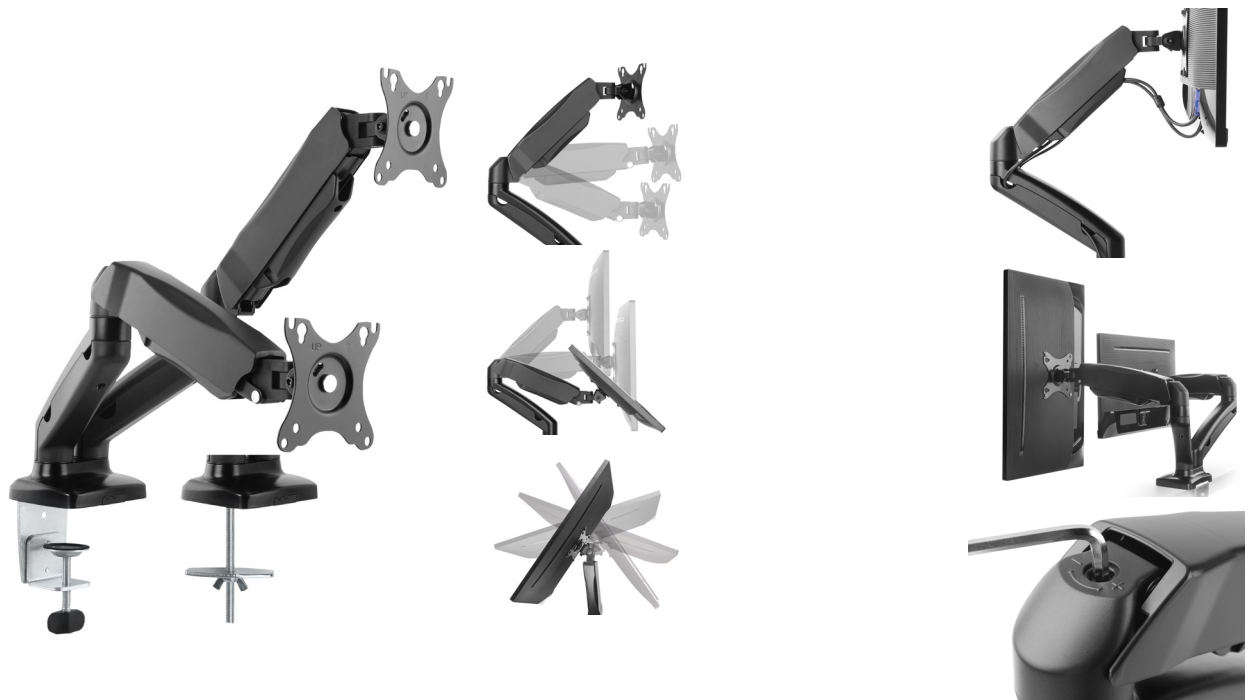

PRODUCT DATA

Product category:	Gas spring monitor arm
Material:	Aluminum, plastic
Surface finish:	Powder coating
Color:	Matte black
Dimensions:	942 x 112 x 590 mm
Fit screen Size:	13"-27"
Fit curved TV:	Yes
Screen quantity:	2
Weight capacity (per screen):	2~9 kg
VESA compatible:	75x75,100x100
Tilt range:	+90°~-45°
Swivel range:	+90°~-90°
Screen rotation:	+180°~-180°
Arm full extension:	450 mm
Installation:	Grommet, clamp
Suggested desktop thickness:	Clamp:10~83mm grommet:10~83mm
USB port:	No
Multi-media port:	No
Cable management:	Yes
Anti-theft:	No
Accessory Kit Package:	Normal/ziplock polybag, compartment polybag

LOGISTICS DATA

Article number:	ARM-1300
Brand:	DELTAACO
EAN code:	7333048044136
Country of origin:	China
Custom tariff number:	83024900
Master carton packing unit:	4 pcs
Master carton gross weight:	18.47 kg
Master carton dimensions:	69 x 36.4 x 32 cm
Package type:	Box
Package weight:	4.38 kg
Package dimensions:	17.2 x 15 x 67.5 cm

PACKAGING

Package contents:	Wall mount, mounting kit for wall, mounting kit for display and manual
-------------------	--



-Image may differ from the actual package

Drawing

